

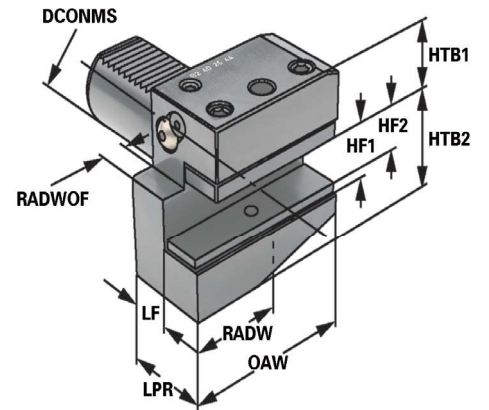

Verwendung:
Vorwiegend für Außenbearbeitung.
Zum Plan Einstechen.

Application:
Mainly for external machining.
For face machining.

Application:
Principalement pour usinage extérieur.
Pour carottage.



Bestell-Nr. Order no. Référence	Abmessung Size Dimension	DCONMS	HF1	HF2	LPR	LF	OAW	RADW	RADWOF	HTB1	HTB2
169.32.12	B2 - 16 × 12 × 24	16	12	-	24	13	42	23	5	20	22
209.32.16	B2 - 20 × 16 × 30	20	16	12	30	16	55	30	7	25	30
259.32.16	B2 - 25 × 16 × 30	25	16	12	30	16	55	30	7	25	30
309.32.20	B2 - 30 × 20 × 40	30	24,5	20,5	40	22	70	35	10	23,5	42,5
409.32.25	B2 - 40 × 25 × 44	40	28	23	44	22	85	42,5	12,5	30	50
509.32.32	B2 - 50 × 32 × 55	50	33	26	55	30	100	50	16	35	60

Ausführung: Mit einstellbarer Kugelspritzdüse und Unterlegplatte
Version: With adjustable spray nozzle and shim
Version: Avec gicleur ajustable et semelle

7





Radial toolholders form B2 left, short - for tools with internal coolant
 Porte-outils radials forme B2 gauche, court - pour outils avec arrosage interne



Verwendung:
 Vorwiegend für Außenbearbeitung.
 Zum Plan Einstechen.

Application:
 Mainly for external machining.
 For face machining.

Application:
 Principalement pour usinage extérieur.
 Pour carottage.

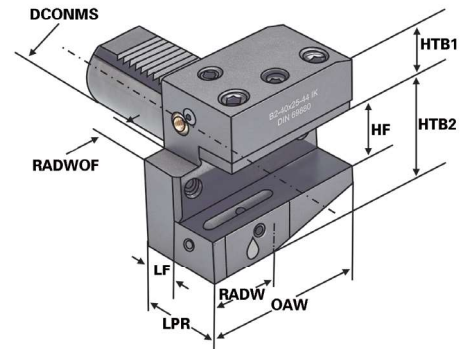

Bestell-Nr. Order no. Référence	Abmessung Size Dimension	DCONMS	HF	LPR	LF	OAW	RADW	RADWOF	HTB1	HTB2
309.32.20.IK	B2 - 30 × 20 × 40	30	20	40	22	70	35	10	28	38
409.32.25.IK	B2 - 40 × 25 × 44	40	25	44	22	85	42,5	12,5	32,5	48
509.32.32.IK	B2 - 50 × 32 × 55	50	32	55	30	100	50	16	35	60

Ausführung: Mit einstellbarer Kugelspritzdüse
Version: With adjustable spray nozzle
Version: Avec gicleur ajustable



Übergabe für Kühlmittel
 Coolant supply
 Jonction d'arrosage

